

# Non-symmetry and the consistency of analogical and case-based reasoning

Antoine CORNUEJOLS

Equipe Inférence et Apprentissage  
Laboratoire de Recherche en Informatique (LRI), UA 410 du CNRS  
Université de Paris-sud, Orsay  
Bâtiment 490, 91405 ORSAY (France)  
email (UUCP) : antoine@lri.lri.fr

## Abstract

If we consider analogy as a function mapping a source and a target to a new case (corresponding to the solved target), then an analysis of this function shows that it presents three properties not mentioned so far in the literature viz (i) non-continuity/non-linearity, (ii) non-idempotency, and (iii) non-symmetry. After discussing these properties and giving some examples, we argue that they may have profound implications regarding the feasibility of Case-Based Reasoning, and especially its consistency. In addition to bringing this problem to awareness, this paper tries to provide hints as how one may avoid the associated pitfalls.

Submitted to ECAI-92

Topic : Principles of Artificial Intelligence Applications

Long paper

# 1. Introduction

In domains where a strong theory is available, a system can rely on standard logical inferencing for reasoning and on some kind of Explanation Based Learning (EBL) for learning. In domains where almost no background knowledge is explicit, a system must rely on inductive methods bearing on some bias and many observations to discover some regularities in the data and use these as a basis for reasoning. Most domains however fall between these two extremes : lot of background knowledge is available but generally it is not sufficient to allow pure deductive reasoning and some form of induction is required to "fill the gaps", the system must then exploit as much as possible the preexisting imperfect domain knowledge inductively. One of the key methods here is analogy together with its close relative popularized within Artificial Intelligence as Case-Based Reasoning (henceforth CBR).

Definitions and mechanisms for analogy will be the concerns of section 2, but roughly speaking, analogy can be seen as inferring that resemblance in some respects entails resemblance in some other aspect(s). This is a powerful method when no deductive reasoning is possible and when one looks for as tight constraints as possible on its search through the hypothesis space. Unsurprisingly therefore, analogy pervades all quarters of reasoning and learning. One finds it in communication settings where, like metaphor, it helps to convey saliencies to heretofore present but unnoticed features of the object, problem or situation at hand. It profits also to problem solving activities either through direct comparison of descriptions or through the comparison and transfer of past solution paths [Carbonell,86]. In learning it helps focusing on the likely relevant features. And with the growing demand for intelligent computer assistance (e.g. in medicine, law, diagnostic and so on) and the increasing realization that most expertises consist of large libraries of cases (that, in addition are more easily transmitted), there has been recently a move towards the development of Expert Systems using cases analogically instead of rules deductively. These systems have been dubbed Case-Based Reasoners and they are to occupy a growing place among AI systems.

Accordingly, research has been very active in this area during recent years. It is useful to split these studies along the main pending questions,

either of a more theoretical stance :

- identification of the main types or modes [Indurkha,89] of analogy,
- justification (logical or statistical or else) of the value of analogical inferencing [Davies & Russell,87],[Russell,89],[Loui,89]

or more heuristically oriented :

- how to retrieve useful past case(s)
- how to use past case(s) for solving a new problem or understanding a situation
- how to evaluate and confirm an analogy
- how to repair a faulty analogical extension
- how to store cases in memory

- which new cases to store in memory

Concerning this last question, which importance should rise steadily as CBR becomes more widely spread, too few works, even if noticeable, have been devoted to its study. Of these, the vast majority has concentrated on the problems associated with the acquisition of *one* case in isolation, implying that no specific problems arise with the acquisition of many cases.

However, should we dismiss the matter so quickly ? Besides the obvious issues associated with the organization in memory of all these cases and the dynamic re-organizations that will unavoidably have to take place from time to time, should we not have concerns for consistency in such incrementally built cases bases ? In other words, and in order to explain what we mean by consistency here, as more cases are acquired by the system, the regions of overlap between cases (i.e. the regions of the problem space where two or more cases could be called upon for solution) will grow. In these regions, will we observe agreement or disagreement between solutions obtained from different cases ? If disagreement seems not to be the exception, then we 'd rather start thinking about ways to reduce these inconsistencies, or, alternatively, about ways of choosing the "right case".

Now it just happens that a careful analysis of the analogical process points to some potential problems with the consistency of analogical reasoning and, subsequently, with the incremental building of cases bases, even in very simple settings. This is these reefs that the research reported here intends to start investigating.

The organization of the paper is as follows. After the introduction, section 2 presents an overview of analogy as can be seen from an Artificial Intelligence point of view. In addition to present problems associated with analogy, this will allow to introduce and justify the framework of the subsequent investigation. Section 3 will then single out three important properties of analogy that went unreported up to now and illustrate them through examples. In section 4 we discuss their implication regarding the consistency of analogical reasoning and the incremental building of cases bases. Finally, section 5 will conclude by examining the constraints under which consistency could be guaranteed.

## 2. Analogical reasoning

At first, analogy can be seen as inferring that resemblance in some respects entails resemblance in some other aspect(s). From the observation of many analogies made by humans it has been noted that there exist several different contexts and uses corresponding to various tasks involving as many types of knowledge and reasoning processes. [Indurkha,89] call them "modes of analogy" and has identified three main ones of them. The first, analogy by rendition consists in seeing or interpreting an object or situation as another object or situation \_therefore, it is hoped, with another frame of reference\_ in order to solve a problem that cannot be solved within the initial or immediate description scheme. This creative problem solving method involves quite difficult questions and is far from being understood, metaphor is one of its guise. The second mode of analogy is proportional analogy where relations like "A is to B what C is to D" are used generally in order to find the term D when the others are known. Lots of works have been devoted to the study of this type of analogy, we will come back to it later on. The third and last mode of analogy, following Indurkha, is predictive

analogy. It refers to "the process of *justifiably inferring*<sup>1</sup> further similarities between two objects or situations based on some existing similarities". This corresponds to the usual use of analogy in Artificial Intelligence where one tries to solve a problem by identifying a similar one with a known solution and drawing from this solution informations required for the solution of the initial problem. Cased-Based Reasoning falls in this category.

However different these modes and all analogies for that matter appear to be, the current view in Artificial Intelligence is that they all embody the same fundamental core mechanism (shown in figure 1).

The incompletely known situation or problem that is to be understood or solved is called the *target*. The (usually supposedly unique) better known situation or problem that is to be used analogically to help solve the target is called the *source*.

It is handy and usually meaningful to depict each of them as a pair of terms that, as the case may be, represent respectively the terms of a problem and its solution whether it be the result only or the whole solution path, or a context and one of its features.

The analogical reasoning exploits mapping relations and dependence relations in order to transpose knowledge from one universe relating to the source to another universe relating to the target. A *universe*  $U$  contains all the knowledge pertaining to a given domain (e.g., in electricity : the description of the various components, formulas like  $u = r.i$ , and mechanisms allowing to infer new knowledge). The way things are described determines the way things are perceived within the universe : this is sometimes called the "*point of view*". Examples of this will be given later.

Given a universe, if (a description of)  $A$  must be present in order to deduce (a description of)  $B$  within a hypothetical theory known or not, then  $B$  is said to be in a *relation of dependence* with  $A$ , which we note  $A \beta \mathcal{O} B$ . In general,  $B$  is anything that we are looking for, and  $A$  is what determines in one way or another  $B$ .

In the same way, when a mapping relation has been set up between two descriptions of objects or of dependence relations, then we say that these descriptions are in a *relation of correspondence*, which we note  $A \alpha \mathcal{O} A'$ .

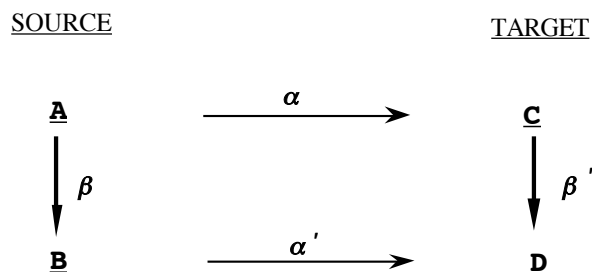

Figure 1: A general schema accounting for analogy.

Analogical reasoning in its generality involves several problems :

---

<sup>1</sup> The italics are from Indurkhya.

- choosing an appropriate source
- choosing an appropriate point of view both for the source and for the target
- determining the correspondence between the source and the target in order to select what to transfer
- knowing how to adapt what has been transferred in order to solve the target
- and checking the validity of the analogy.

These problems are interdependent and cannot be kept separate. For instance, choosing an appropriate source generally involves some kind of distance metrics between the "cases", which in turn depends on the point of view that has been retained. The correspondence between the source and the target is itself highly dependent upon the point of view, as will be illustrated later. So far, the considerable works devoted to analogy have brought only partial solutions to these questions, but it is to their credit to have uncovered and highlighted the difficulties and the intricate issues at stake. In the following, we review the findings of some prominent works.

One work on analogy which is on the "neat" side is the one reported in [Davies & Russell,87] and in [Russell,89]. The intention of this work is to provide a justification for the use of analogy and, correlatively, to give conditions for its justified use. The authors justly reject the amount of similarity between the target and the source as a basis for the plausibility of analogical inference. Given a studied red robin and an uncompletely seen one, one should be much more happy to infer that the unseen one will have roughly the same body proportions than to infer that it will also have a scratched beak, even though in both cases the amount of similarity between the source and the target is the same. Obviously there is some other knowledge at work here that says how similarity is relevant to certain conclusions and not others. However, this knowledge should be weaker than plain logical implication, otherwise that would mean that the source is not useful, and that the theory alone would be sufficient to draw the sought after conclusions. This is what Davies and Russell call the non-redundancy problem : the source should be necessary to the analogical inference, in addition to the theory.

To this problem of the logical justification of analogical inference, they propose *determination rules* as a solution. Determinations are weaker than logical implications, they are also considerably restrictive on what kind of analogical inference can be drawn as we will show in a moment. Determinations are weaker than logical implications because they do not give rules that allow to answer queries given the relevant facts in general. For each query that can be answered analogically (e.g. *NativeLanguage(Jack,x)*), there exists a determination rule (e.g. *Nationality(z,n) @ NativeLanguage(z,l)*) that splits in effect the world into classes relatively to the characteristics that determine the answer to the query (e.g. *Nationality(z,n)*), where each class is such that all its elements share the same value for the characteristics (e.g. the class of the English people, the class of the Chinese, and so on). Now, to answer the query, one has to identify the relevant determination rule, to find a source that belongs to the same class as the target relatively to the determining characteristics, and to look in this class at the answer to the query (e.g. the class of the English people, to which Jack supposedly belongs, contains also Jill, and her NativeLanguage is English, hence the NativeLanguage of Jack must be English as well).

In other words, for each query for which there exists a (unique) determination rule, this one specifies along which characteristics to split the world into classes. Then, it remains to find a source in the same class as the target and to read the answer to the query for this source as the answer for the original query.

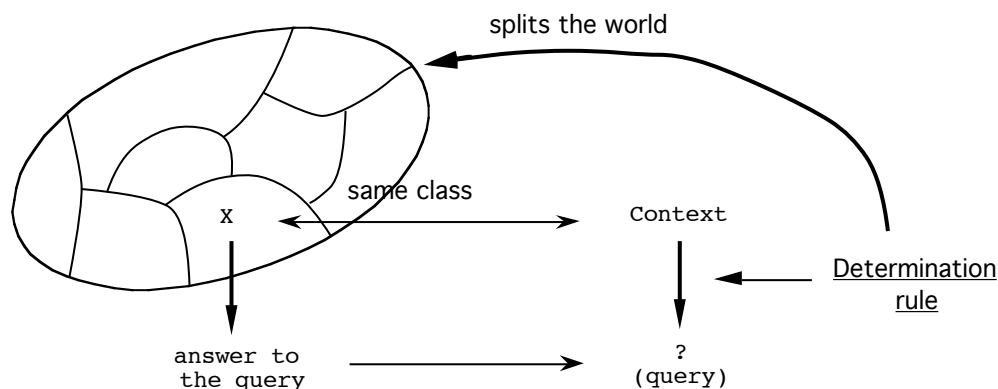

The relation of correspondence here is determined through the query and its associated determination rule, it corresponds to the definition of the classes. The source and the target are in a relation of correspondence if and only if they belong to the same class. The source is therefore any case that belongs to the same class as the target. The relation of dependence is then the determination rule instantiated for this specific class, and it is the same for both the target and the source as well as for all members of the class.

This framework imposes quite strong contingencies on analogy. First of all, for each query, there is at most only one determination rule. For instance, it is not possible to say that the native language of someone can depend either on its country of residence or on the language of her parents. To be more precise, nothing a priori would prevent the existence of several determination rules for the same query, but nothing is said about how one would go to choose among these. Second, it is implicit in the presentation of the determination rules that there is no choice regarding the point of view along which the target and source are perceived and represented. Unfortunately, this is precisely the determination of this point of view that is a major difficulty in analogical reasoning, as we will see when examining the works of Hofstädter and his co-workers. This problem is simply evacuated in the presentation of [Davies & Russell,87]. To sum up, Davies and Russell have very neatly presented the problem of the justification of analogical reasoning, the solution they propose however is not satisfactory because it ignores most of the subtleties and richness present in analogy.

Hofstädter and his colleagues have approached the problem of analogy in a quite different way. Convinced that it was far too complex to yield all of its "mystery" to a principled way attack, they started by designing a world that would capture most of the intricacies of analogy and yet would be simple enough so as to allow lot of experiments and variations and plainly plays to be carried on. The result is a micro-world ([Hofstädter,85]) where the game is to find the fourth term in a proportional analogy between sequences of letters or numerals. The two following examples illustrate the components and the rules of the world.

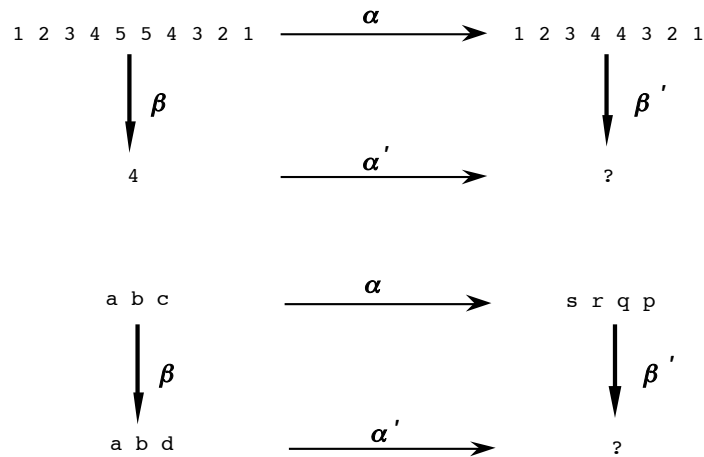

While solving this type of problems, one must look for the relation of dependence  $\beta$ , the relation of correspondence  $\alpha$ , and the relation of dependence  $\beta'$  that will allow to determine the fourth term D. One of the key insight here is that  $\beta$ ,  $\alpha$ , and  $\beta'$  are highly interdependent. The problem is foremost one of perception : how to perceive \_and represent\_ the source and the target in order to best explain one  $\beta$  and simultaneously account for one  $\alpha$ , knowing that  $\beta'=\alpha(\beta)$ . This last equality sums up the credo of Hofstadter that analogy making is seeing the "same roles" at play in two situations, with the roles (or modules of description) in the target being the same as the ones perceived in the source, but translated through the relation of correspondence  $\alpha$ .

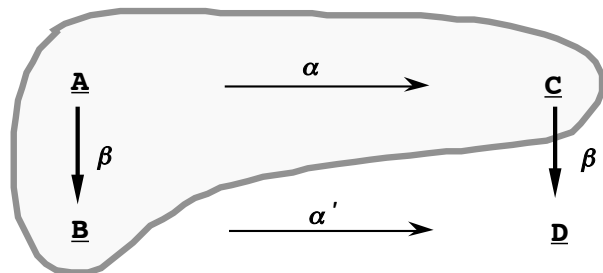

Most difficulties associated with analogy are present in this simple framework. If one does not need to look for a source, in return one has to single out an appropriate relation of dependence in the source, and then determine, through a relation of correspondence to be found between the source and the target, how to transfer it to the target.

[Hofstadter et al.,87] propose to look at this problem as a kind of constraints satisfaction problem where various "pressures", stemming from the way things are naturally perceived and resist to changes of representation, are to be accommodated at best. The search for an optimal choice involves a semantic net called a slipnet where the concepts are linked through various relations of different abstraction levels, and a stochastic optimization process.

We are not interested in this scheme here, but we will use the micro-world to make experiments and uncover several intriguing features of analogy. Furthermore we will assume

that for each analogical problem presented there is a unique best solution and that we know it<sup>2</sup>.

### 3. Non-symmetry in analogy

In order to have a uniform formalism in which to express the characteristics of analogy we wish to underline, we will look at analogy in the afore-mentioned micro-world as a function  $f$  taking three arguments defining the analogy problem :  $A, B, C$ , and returning two arguments corresponding to the answer :  $C$  and  $D$ . (e.g.  $f(abc,abd,srqp) = (srqp,trqp)$ ).

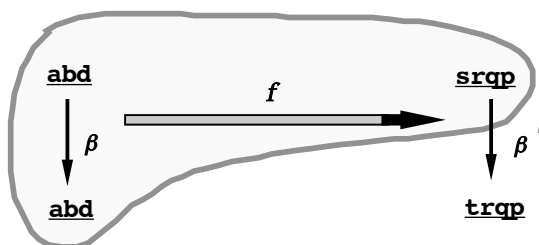

Now, we can look at some properties of  $f$ , and thus of analogy.

#### 3.1. Discontinuity and non-linearity of $f$

Important properties of functions are revealed by their regions of discontinuity and non-linearity. If we take  $f$  as a function of the three arguments  $A, B$  and  $C$ , it is tempting to look at the way the result  $D$  varies depending on their variations. For instance, one can slightly modify  $B$ , or  $C$ , (therefore modifying respectively  $\beta$  or  $\alpha$ ) and then examines the resulting evolution of  $D$ . If it is a "smooth" one, then we are in a region of continuity. But it can happen that  $D$  undergoes a brutal variation when  $B$  or  $C$  is slightly modified, and that uncovers a discontinuity.

---

<sup>2</sup> We could as well use the program COPYCAT of [Hofstader et al.,87] and look at the proportion of runs it chooses each interpretation, and decide from this which is the best one.



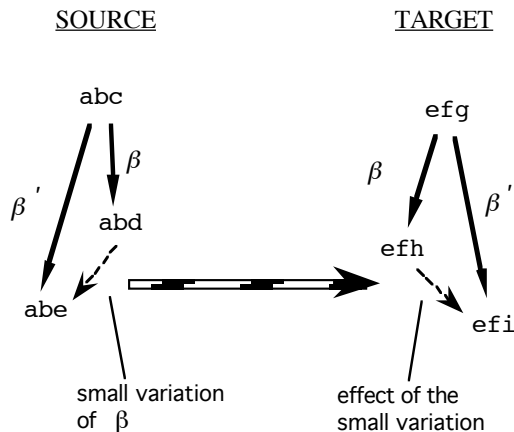

The above example gives the flavour of this, it does not, however, fully account for its complexity. The problem is foremost the recurrent one of *measuring the proximity of two cases* or two descriptions in order to provide a definition to what we call a small variation in *B*, *C* and *D*. There exist several possibilities regarding this definition.

The first one and most immediate is to define proximity between cases from a notion of distance between their descriptions. For instance, in the slipnet proposed by [Hofstadter et al.,87], each link between nodes (e.g. *opposite*, *symmetric*, *successor*,...) is labelled with a numeric coefficient representing its length<sup>3</sup>. It is therefore conceivable to compute the distance between two descriptions by summing the lengths of the intervening links between the two. Of course, this would mean that this distance is dependent on the chosen representation, and it would require that there is a unique way to modify one description into another in the representation (otherwise the intervening links between two descriptions would depend on how the modification is considered). Following this suggestion, *abc* is "closer" to *aabbcc* than *abc* is to *cba* if the link between *letter* and *group\_of\_letters* is shorter than the one between *successor* and *predecessor*. Lots of difficulties, however, appear when one tries to elaborate more fully on this solution.

Another suggestion is to consider that two situations are all the more closer that the number of dependence rules that can apply to both of them in the same way is larger. For instance, the situations *abc* and *efg* are closer than the situations *abc* and *xyz* because in this last case, the rule "replace the rightmost letter by its successor" can not be applied literally to *xyz* and must be translated as "replace the leftmost letter by its predecessor".

In any case, it is obvious that there are contexts in the micro-world where discontinuity arises. For instance, while the rule "replace the rightmost letter by its successor" applies without trouble to all situations described by "a sequence of three successive letters" (e.g. *efg* or *pqr*), it ceases to apply *\_in this form, but not in spirit\_* to the situation *xyz*, and must be translated *\_in accordance to the spirit of the former rule\_* into "replace the leftmost letter by its predecessor". This illustrates a discontinuity with respect to the correspondence relation  $\alpha$ . The heuristic here is that discontinuity occurs when the concepts entering in the description of

<sup>3</sup> In fact, each link is itself a node, and the activation (a measure of its relevancy and importance in the current description of the analogy) determines its length.

$\alpha$  changes. The same heuristic works to characterize discontinuities with respect to the dependence relation  $\beta$ . This is due to the fact that  $\alpha$  and  $\beta$  are highly interdependent, which explains non-linearity and discontinuity. It therefore happens that sometimes changes in  $\beta$  force changes in  $\alpha$  at the same time (e.g. when the source is  $abc \emptyset abd$  and the target is  $wxy$ ,  $\alpha$  can be "every thing corresponds except that each letter must be replaced by its 22nd successor" and  $\beta$  as "replace the rightmost letter by its successor". Now if the source changes to  $abc \emptyset abe$ ,  $\beta$  is changed to "replace the rightmost letter by its 2nd successor, and  $\alpha$  must be changed radically because  $\beta$  does not apply anymore to the the target  $wxy$ .  $\alpha$  might then become "letter $\leftrightarrow$ succ<sup>22</sup>(letter), successor $\leftrightarrow$ predecessor, rightmost $\leftrightarrow$ leftmost" which will allow the translation of  $\beta$  into  $\beta'$  : "replace the leftmost letter by its 2nd predecessor" yielding the solution to the target :  $uxy$ ).

Another way of looking at the discontinuity areas is to examine the target and its solution. The particularity of the case  $xyz \emptyset wyz$  is that it is both an instance of the dependence relation : "replace the rightmost letter by its successor", and of the relation "replace the leftmost letter by its predecessor". The same (!) is true of the case  $wxy \emptyset uxy$ . Each time a case can be seen along different points of view, discontinuity can occur.

### 3.2. Non idempotency of f (fof $\neq$ f)

The following figure clarifies better than a long speech what is non-idempotency. This is very close in spirit to non-transitivity.

$$f(f(abc,abd,xyz),pqr) = (pqr,oqr) \neq f(abc,abd,pqr) = (pqr,pqs)$$

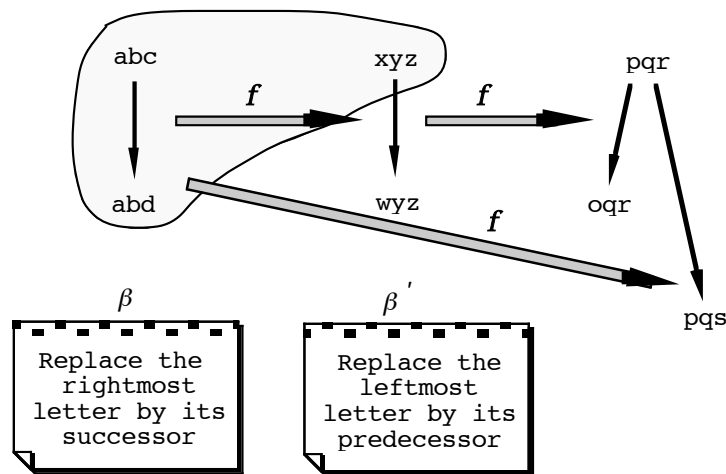

### 3.3. Non-involution (fof $\neq$ Id) and non-symmetry of f

Let's examine now if the function  $f$  is involutive (i.e.  $fof = Id$ ). A single example will suffice to show that such is not the case.

$$f(f(bcd,bce,xyz),bcd) = (bcd,acd) \neq (bcd,bce)$$

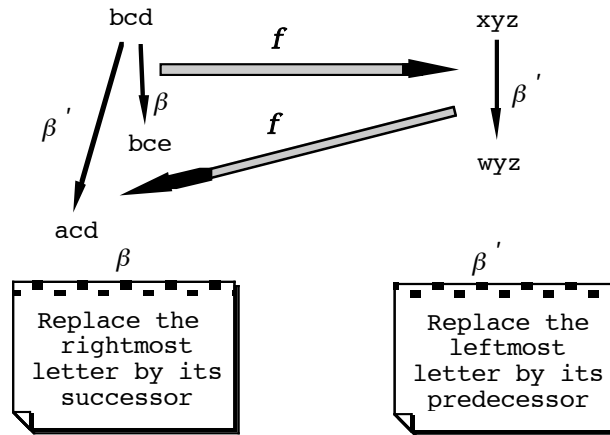

This same example proves that  $f$ , and thus analogy, is not symmetric.

Once again, the reason behind this is that the initial dependence rule  $\beta$  ("replace the rightmost letter by its successor") is changed at an intermediate step (here when applied to the situation  $xyz$ ), and then is applied in this modified form to the first situation (here  $bcd$ ) resulting in a different solution ( $acd$ ).

In studying further the problem of symmetry, one can identify three classes of possible behaviors. The (thought-)experiment setting is the following : let's say that one starts from a known case to solve a given situation. A result is so obtained. Assume now that this situation and its solution be considered as a known case, and that the solution to the initial case is now forgotten. See then which solution you will get using the new known case to solve analogically the situation of the forgotten case. If the solution thus obtained is the same as the former one, then analogy is symmetric for these two cases, otherwise it is non symmetric. In this last circumstance, it is interesting to push the game a few more steps, and two classes of behavior are then possible : a limit cycle or an infinite flight.

The following diagram depicts graphically these three classes.

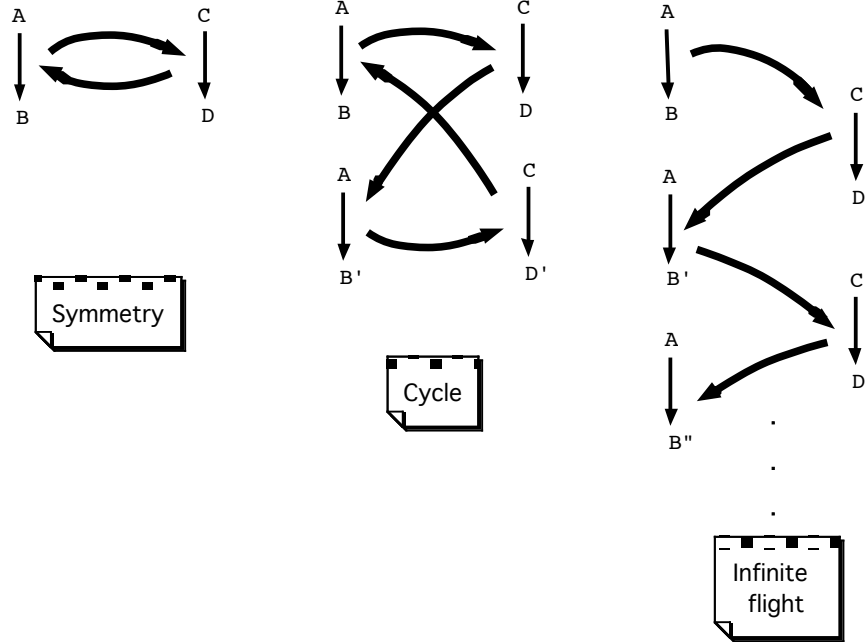

The author has found examples of class 1 and 3 in the micro-world, but not, so far, of class 2.

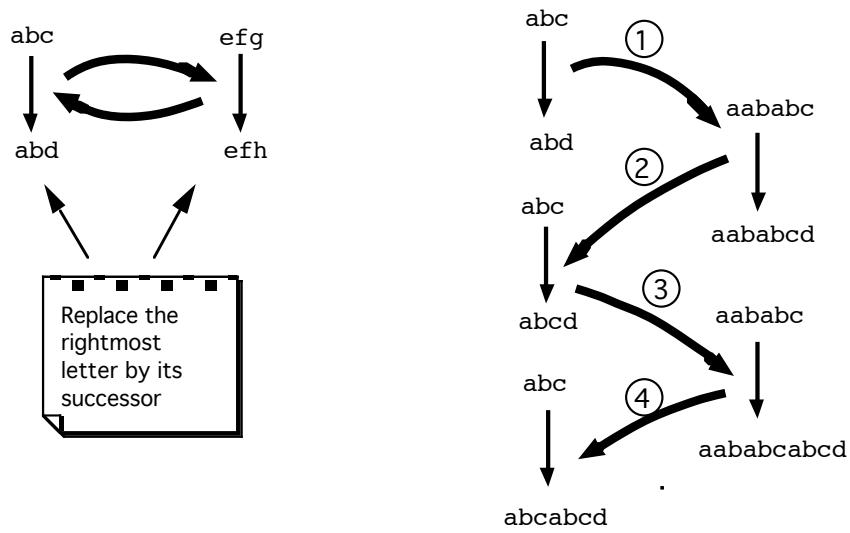

- 1: Identify each letter with a group of letters a<->a, b<->ab, c<->abc, and replace rightmost group by its successor : abcd
- 2: Replace abc by abcd
- 3: Make the identification as in 1, and add to the end of the sequence the successor of the rightmost group : abcd
- 4: Replace abc by abcabcd

## 4. Consequences

### 4.1. Of the discontinuity and non-linearity of $f$

The principal consequence of the discontinuity and non-linearity of analogy for in a CBR perspective is that two cases that may appear quite close of each other may in fact reveal altogether different when used to solve a target. This is in fact not surprising. This simply shows in a different light that analogy (i.e. taking superficial resemblances as signs of deeper ones) is not a full-proof inference mechanism. It is nice however to keep being reminded of this.

### 4.2. Of the non idempotency of $f$ ( $f \circ f \neq f$ )

That analogy be not idempotent may have profound consequences on the feasibility of CBR. First, it shows indeed that circumstances may exist in which one problem, that can potentially be solved using one source or another one<sup>4</sup>, the latter obtained and derived from the former, can get different answers depending on which source is used. In other words, the answers produced by a CBR system may not be consistent even though the cases base was acquired automatically, each new case deriving from a former one ! Second, it points also to the fact that the order in which cases are examined and then acquired by a system can make a lot of difference in its future performance.

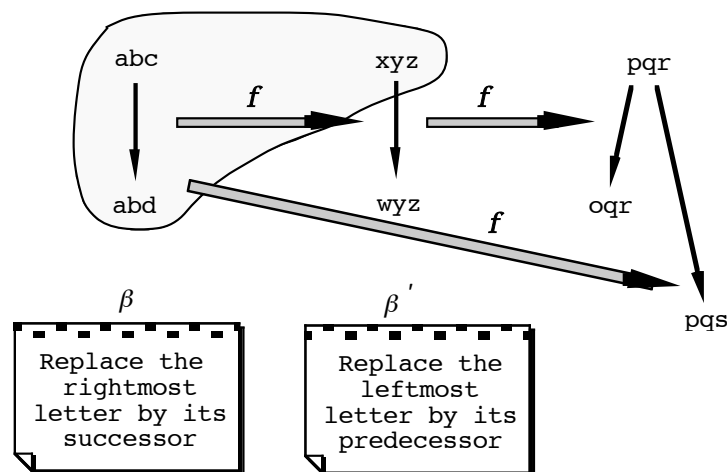

Now the question is : do these examples from the micro-world and for this peculiar kind of analogical reasoning (where really cases are no more than an initial situation and the corresponding solution without the dependence relation  $\beta$  that has to be found) carry any implication for the more mundane kinds of CBR where cases are far more elaborated and known in details ?

<sup>4</sup> We do not look here at how relevant cases are determined, we assume that some mechanism (based on similarity or any other scheme like the one of [Davies & Russell,87]) is in charge of this problem.

In fact, the distinction between the micro-world and the "real" one is not so deep, and this is the claim and justification of Hofstädter. Indeed, the whole argument would still carry over if one assumed that cases in the micro-world include the dependence relation  $\beta$  (e.g. if the rule "replace the rightmost letter by its successor" was provided along with the situation *abc* and its solution *abd*). The reason is that the non-idempotency and the correlative property of non-symmetry do not depend on the relation  $\beta$ , but on the way this one is translated, via  $\alpha$ , from one context to the other, and this remains a problem, and a crucial one at that, in common CBR. Therefore the same phenomenon could be observed there as well.

On the other hand, it is interesting to note that this problem of consistency could not appear with analogical reasoning based on the determination rules of [Davies & Russell,87] because in their framework the source and the target belong to the same class and no translation must be made to adapt the dependence relation from one case to the other.

### 4.3. Of the non-involutivness (f of $\neq$ Id) and non-symmetry of f

Non-symmetry is closely related to non-idempotency, this is really a special case of the latter. It is possible nonetheless to point out to specific consequences of this property. One is that reconstructive memory (reconstructing an episode or a case from the rest of memory when it has been forgotten) is not a simple matter in cases bases, and this even when the cases have been derived from each other as circumstances and problems encountered dictated. It is thus quite possible to reconstruct a different case from other cases in memory even if these sources were at first derived from the case that is reconstructed. For instance, if the case *bcd* $\emptyset$ *bce* was forgotten, and one tried to reconstruct it from the problem *bcd* and the case *xyz* $\emptyset$ *wyz* that was first derived from *bcd* $\emptyset$ *bce*, then one would get a different case *bcd* $\emptyset$ *acd*. This may reveal a real problem as cases bases will grow substantially in size and as forgetting will occur either as accidents or purposefully. The expertise of the CBR system could then shift slowly toward something different.

## 5. Conclusion

In this paper, we have shown that as soon as the universe where Case-Based Reasoning is employed is sufficiently rich so as to allow the possibility for multiple points of view, one may encounter non-continuity, non-idempotency and non-symmetry of the analogical process. These properties, that are the telltale of non trivial analogies, mean also that reasoning becomes full of hazards. Even with cases acquired automatically over time and "derived" from other cases in memory, inconsistency in the results provided by CBR can arise. Thus, depending on the source that is chosen, and more importantly and baffling, depending on the order in which cases were met and acquired during the life of the system, the solution to a problem may vary.

An answer to this threat is to restrain considerably the scope of analogical reasoning so as to eliminate the possibility of multiple points of view. This is what is done with the use of determination rules. It would be better, however, if less crude ways out existed. At present, few tracks signal themselves. A better understanding of the three classes of behaviors pointed out in section 3.3 (possibly in terms of conservation of information) could lead to such paradises and to a more controlled reasoning and learning with cases bases.

## References :

- Carbonell Jaime** (1986) : "*Derivational analogy: A Theory of Reconstructive Problem Solving and Expertise Acquisition*". In Machine Learning: An Artificial Intelligence Approach (vol.2), Michalski, Carbonell, Mitchell: eds. Morgan Kaufmann, 1986, pp.371-392.
- Davies & Russell** (1987) : "*A Logical Approach to Reasoning by Analogy*". In Proc. of the 10th International Joint Conf. on Artificial Intelligence (IJCAI-87), Milano, 1987, pp.264-270.
- Hofstädter Douglas** (1985) : *Methamagical Themas: Questing for the Essence of Mind and Pattern*. Basic Books, 1985. See chapter 24 : "Analogies and Roles In Human and Machine Thinking", pp.547-603.
- Hofstädter, Mitchell & French** (1987) : "*Fluid concepts and creative analogies: a theory and its computer implementation*". University of Michigan, Fluid Analogies Research Group, document 87-2, march 1987.
- Indurkha B.** (1989) : "*Modes of Analogy*". 2nd International Workshop on Analogical and Inductive Inference AI'89, pp.217-230.
- Loui R. P.** (1989) : "*Analogical Reasoning, Defeasible Reasoning, and the Reference Class*". In Proc. of the 1st International Conf. On Principles of Knowledge Representation and Reasoning (KR'89), Toronto, 1989, pp.256-265.
- Russell Stuart** (1989) : *The Use of Knowledge in Analogy and Induction*. Pitman, 1989.